

# OWNER'S MANUAL

## Model: FT-200-4R (5303634)

(200 Gallon Fire Trailer w/127cc B&S Engine, 4-Roller Pump & Banjo 3/4" Nozzle)

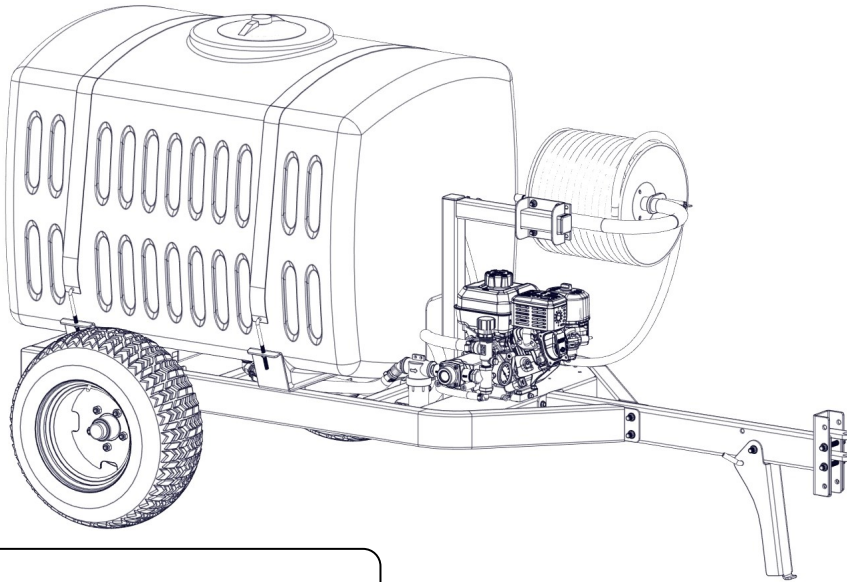

**WARNING:** Cancer and Reproductive Harm.  
[www.P65Warnings.ca.gov](http://www.P65Warnings.ca.gov)

### General Information

Thank you for purchasing this product. The purpose of this manual is to assist you in operating and maintaining your trailer sprayer.

**BEFORE RETURNING THIS PRODUCT  
FOR ANY REASON, PLEASE CALL**

**1-800-831-0027**

MONDAY-FRIDAY, 8:00 AM TO 5:00 PM CST

If you should have a question or experience a problem with your Fimco Industries Product: Visit our website @ [www.fimcoindustries.com](http://www.fimcoindustries.com) or call the Toll free number above. Our technical support representatives will be happy to help you.

In most cases a customer service rep. can resolve the problem over the phone.

To obtain prompt, efficient service, always remember to give the following information....

- Correct Part Description and/or part number
- Model number and Serial Number

Part descriptions and numbers can be obtained from the illustrated parts list section(s) of this manual.

**Retain a copy of your receipt for your unit, as it will be required to validate any warranty service.**

**Warranted against manufacturer or workmanship defects from date of purchase with copy of receipt:**

**Homeowner Usage: One Year.**

**Commercial Usage: 90 Days.**



### NOTE:

Maximum Speed (Empty) - 10 MPH

Maximum Speed (Filled) - 5 MPH

Refer to vehicle's manual for towing instructions.



**WARNING:** To reduce the risk of injury, the user must read and understand the operator's manual before using this product.

### IMPORTANT REMINDER:

Add proper oil to the engine crankcase and gasoline to the gas tank. Refer to the engine manual for the correct type and amount.

### \*\*\*WARNING\*\*\*

This product when used can be dangerous and can cause bodily harm, if not properly used or guarded.

**\* STAY AWAY FROM EQUIPMENT  
WHEN IT IS IN OPERATION \***

Read information and the full instructions furnished with the product before installing and operating.



[www.fimcoindustries.com](http://www.fimcoindustries.com)

1000 FIMCO Lane, P.O. Box 1700, North Sioux City, SD 57049  
Toll Free Phone: 800-831-0027 : Toll Free Fax: 800-494-0440

[5195730

(10/22)]

## Contents

Technical Specs .....	2	Pressure Relief Valve Exploded View/Parts List.....	7
Sprayer Assembly Instructions .....	3	Banjo Garden Hose Nozzle Info.....	7
Operation and Maintenance .....	3 - 4	Sprayer Exploded Views.....	8 - 10
Tank Care and Winter Storage .....	5	Sprayer Parts Lists.....	9
Roller Pump Exploded View/Parts List .....	5	Sprayer Dimensions .....	11
Roller Pump Troubleshooting.....	6	Warranty .....	12

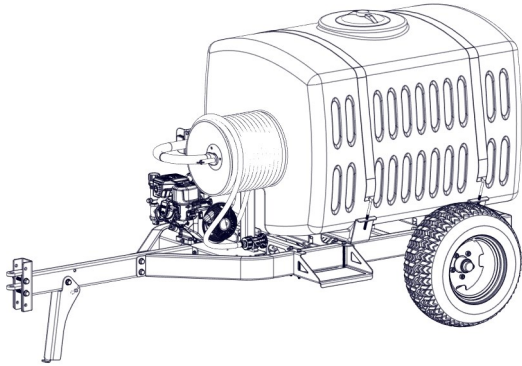

**Model: FT-200-4R (5303634)**  
(200 Gallon Trailer Sprayer w/127cc B&S Engine,  
4-Roller Pump & Spray Nozzle)

### Technical Specifications

- 127cc B&S Engine
- 4 Roller Pump - 6 G.P.M.
- Pressure Relief Valve
- Banjo 3/4" Garden Hose Spray Nozzle
- 1/2" x 100' Hose (600 PSI)
- Tire/Rim, 23" x 1050-12, 4-Ply
- Maximum Speed - 10 MPH

**Caution: When fully filled with water, this sprayer will weigh approx. 2,175 lbs..**  
**Consult the owner's manual for your vehicle to verify that you are within it's load carrying capacity.**

### ~~~~~IMPORTANT~~~~~

Remove tank lid and be sure the tank is clean and free of any foreign material. Rinse tank out of any tank residue before filling with water to test.

### ~~~~~IMPORTANT~~~~~

It is VERY important to test this sprayer with plain water before actual spraying is attempted. This will enable you to familiarize yourself with the sprayer and check for leaks without the possibility of losing any expensive chemicals.

### ~~~~~WARNING~~~~~



**Read and Understand** the Owner's Manual before using this sprayer. Test and use in accordance to instructions.  
**Read and Follow** chemical label instructions and wear protective gear when filling, using, cleaning and servicing the sprayer.

**Exercise Caution** in vehicle handling when towing/hauling a filled sprayer to avoid loss of control or overturning.

**Keep Sprayer and Spray materials** away from other people, children and pets.

**Do Not Turn on Power** to the sprayer, until ready to spray in order to avoid unintentional spray release.

**Do Not Use** on steep slopes. A full sprayer could cause loss of control or overturn sprayer and vehicle.

**Always operate** up and down a slope, never across the face of a slope.

**Keep all movement on slopes** slow and gradual. Do not make sudden changes in speed, directions or turning. Do not start or stop suddenly when going uphill or downhill.

**Stop on level ground**, set the parking brake and shut off engine before leaving the operator's position for any reason.

**Keep all parts** in good condition and properly installed. Fix damaged or worn parts immediately.

**Caution should be taken** when towing and/or using any sprayer. This sprayer combined with the weight distribution, turning radius and speed of vehicle can result in damage to vehicle and/or sprayer or severe injury or death, if not used properly.

**Improper use of this sprayer or handling of chemicals could result in serious injury or illness, or could cause damage to the environment.**

### ~~~~~IMPORTANT REMINDER~~~~~

ADD proper oil to the engine crankcase and gasoline to the gas tank. Refer to the engine manual for the correct type and amount.

## Assembly Procedure

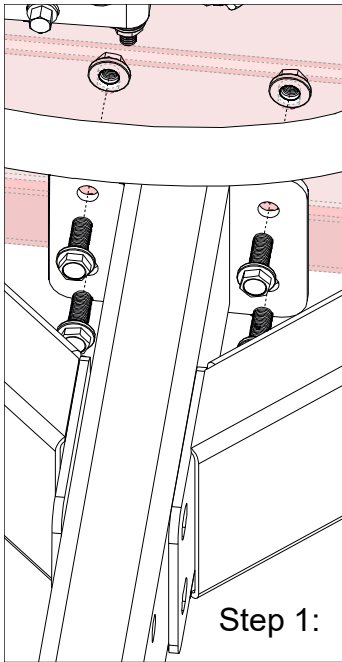

This sprayer is mostly assembled at the factory. Follow the steps on below to properly complete assembly of the sprayer.

The step will already be assembled to the frame, but it can be removed and placed on other side if preferred.

Attaching the tongue to the trailer frame.  
Locate the bolt bag and follow instructions below.

Step 1:

Attach the tongue to the trailer frame with (4) flanged hex bolts & (4) flanged hex nuts as shown.

Step 2:

Secure the tongue to the front part of the frame, as shown, using the remaining flanged hex bolts and (2) flanged hex nuts.

- Make sure all hose clamps are tight before testing or spraying for the first time.

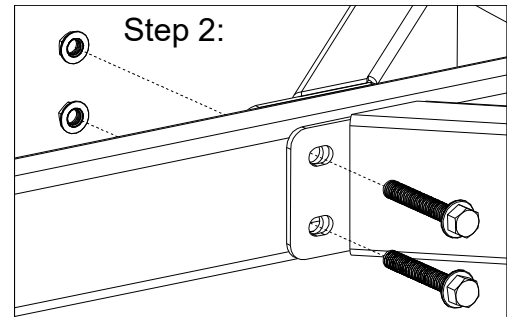

**\*\*The Sprayer is now ready to TEST  
w/plain water before actual use\*\***

**IMPORTANT:** Remove tank lid and be sure the tank is clean and free of any foreign material. Rinse tank out of any tank residue before filling with water to test.

### Testing the Sprayer

#### **NOTE:**

It is important to test this sprayer for leakage and proper spray patterns with plain water before chemical application is attempted. This will also give you the opportunity to familiarize yourself with the operation of the sprayer, without the possibility of losing any expensive chemicals.

1. Fill the tank about 1/2 full with plain water.
2. Open the valve in the suction line and allow water to flow to the pump. The valve is located at this point to enable the strainer to be taken apart for cleaning, while solution remains in the tank.

**CAUTION:** Always be sure that the water (or solution) has reached the roller pump before starting your sprayer. If the pump is allowed to run dry, serious damage to the pump will result. Do not run your sprayer with the spray nozzle line closed AND the bypass line closed. Doing this will damage the pump.

3. It is always best to start the sprayer at little or no pressure. This sprayer is equipped with a spring loaded pressure relief/ bypass valve. Turn the valve knob out to decrease pressure and in for increased pressure.

The bypass valve is the “pressure control” for the entire plumbing system. The more the valve is open, the lower your line pressure. Almost fully closed provides maximum pressure to your boom and/or spray nozzle. **NEVER run your system with this valve 100% closed.**

4. You may now start the sprayer engine following the engine manufacturers instructions. Let the sprayer run at low pressure until water has reached the spray nozzle and all air has been purged from the system.

**Caution:** Care must be taken, being sure the spray nozzle is secured in the operators hand. If this is not done a recoiling action may occur causing damage or personal injury.

5. The pressure should now be increased to 30 - 125 PSI. Operate the sprayer at this increased pressure for 3 to 5 minutes, thoroughly testing the unit before adding chemicals.

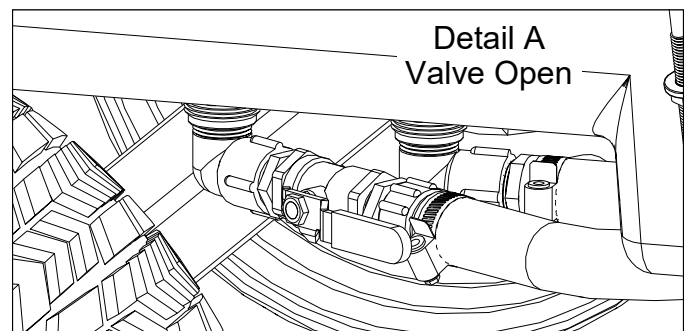

When everything tests all right (no leaks and good pressure), add the desired chemicals to the mixture and water combination and start your spraying operation. Adjust the pressure and spray as you did in the testing procedure. The sprayer should now be ready to use.

**Only fill the tank with what you're going to spray in a day, never leave chemicals sit in tank.**

Conditions of weather and terrain must be considered when setting the sprayer. Do not spray on windy days. Protective clothing must be worn in some cases.

**Be sure to read the chemical label(s) before application!**

#### **Priming the pump**

To help prime the pump, keep the inlet or suction line as short as possible with a minimum of bends, elbows and kinks. Make sure all connections are tight and do not leak air. Make sure the line strainer is free of debris. If pump does not self-prime, disconnect suction hose, fill with water and reconnect to liquid source. Often a squirt of oil into the ports of the pump will seal clearances and help priming. Facing the pump, the suction port is on your left.

#### **Maintenance During/After Spraying**

Periodically close the suction line valve and check the line strainer and clean the screen. Stop the engine and shut off the valve near the strainer. Remove the bowl and screen portions of the strainer and wash them free from all impurities. You may also drain the tank by uncoupling the suction line near the strainer. Open the valve and pour the contents into another container. Read the chemical label for disposal instructions.

Proper care and maintenance will keep your pump wear at a minimum and will keep it running smoothly and trouble-free for a long time and prolong the life of your sprayer.

After use, fill the sprayer tank part way with water. Start the sprayer and allow the water to pump through the entire plumbing system and nozzles. Drain and then refill half full with plain water, add the recommended amount of good quality tank cleaner such as FIMCO Sprayer Tank Neutralizer and Cleaner. (If no tank cleaner is available, you may substitute dish soap for this step, about 1-2 oz. per gallon). But a neutralizer/cleaner should be used to thoroughly clean the system. Turn sprayer on and circulate through system for 15 minutes and then spray out through handgun nozzle (and boom nozzles if applicable). Refill tank half way with clean water and repeat. Follow the chemical manufacturer's disposal instructions of all wash or rinsing water.

For the boom (if applicable) remove the tips and screens from the nozzle assemblies. Wash these items out thoroughly. Blow the orifice clean and dry. If the orifice remains clogged, clean it with a fine bristle (NOT WIRE) brush or with a toothpick. Do not damage the orifice. Water rinse and dry the tips before storing.

Flush the pump after each use. One of the common causes of faulty pump performance is "gumming" or corrosion inside the pump. This prevents the rollers from moving freely. Flush the pump with a solution that will neutralize liquid pumped. A rust inhibitor can also be squirted into the ports of the pump. Turn shaft several times to draw protective liquid through pump and coat entire inner surface.

**WARNING:** Never pump corrosive or abrasive liquids as these will cause rapid wear or deterioration of body, rotor, shaft and seals in the pump. Never run pump dry. Some chemicals will damage the pump valves if allowed to soak untreated for a length of time! ALWAYS flush the pump as instructed after each use. DO NOT allow chemicals to sit in the pump for extended times of idleness. Failure to follow this warning will void the product warranty.

**Follow the chemical manufacturer's instructions on disposal of all waste water from the sprayer.**

## Tank Care & Maintenance

**Warning:** Do not use the tank as a container for fuel oils, kerosene, gasoline or any other petroleum distillate product. All polyolefins are softened and permeated by such products. In an enclosed area the vaporization of these materials from the outside surface of the tank could create a dangerous condition.

The tank should not be used as a pressure vessel nor used with chemicals or solutions having a weight of more than 12 pounds per gallon.

Store the tank in a dry dark place when not in use. Storage out of sunlight will prolong the life of the tank.

Do not drop, strike or kick the tank, especially at low temperatures. Tanks become brittle and are subject to cracking at temperatures below 20° Fahrenheit.

Always flush the tank with water and a neutralizing agent at the end of each use, to prevent contamination of solutions.

## Winter Storage

Prepare the sprayer for end-of-season storage by draining all water out of your sprayer, paying special attention to the pump, handgun and valve(s). These items are especially prone to damage from chemicals and freezing weather.

The sprayer should be winterized before storage by pumping a solution of automotive antifreeze (containing a rust inhibitor) through the entire plumbing system. This antifreeze solution should remain in the plumbing system during the winter months. When spring time comes and you are preparing your sprayer for the spray season, rinse the entire plumbing system out, clearing the lines of the antifreeze solution.

Proper care and maintenance will prolong the life of your sprayer.

It is nearly impossible to drain all of the water from the sprayer and any trapped water can freeze in cold weather and damage parts of the sprayer. Pumping the antifreeze through the system will displace the water and help prevent this damage.

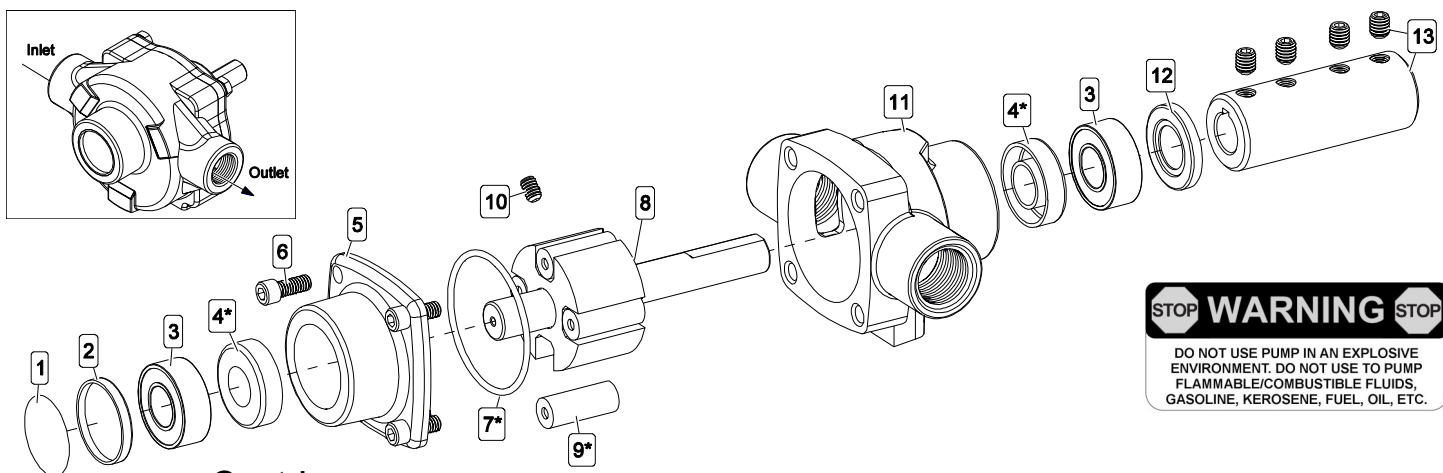

### Cast Iron

### 4-Roller Pump Assembly

#5273020 (Hypro Mfg. Part #: 4101C-01)

For electric motor drive:

Output to 9 GPM, Pressure to 150 psi,  
Speed to 1800 RPM, Temperature to 140°F.

For gas engine drive:

Output to 7 GPM, Pressure to 150 psi,  
Speed to 2600 RPM, Temperature to 140°F

\* \* = Parts Available ONLY in Repair Kit

#7771796 (Mfg. #3430-0390)

Consists of Rollers, O-Ring & Viton Seals

◆◆ = Only Available in Complete Assembly

Ref. #	Part #	Mfg. Part #	Description	Qty
1	---	---	Pump Model Sticker/Label	1
2	5017481	2300-0021	Bearing Cover	1
3	5031113	2000-0010	Ball Bearing (Sealed)	2
4*	**	2107-0002	Seal (Viton)	2
5	◆◆	0200-4101C	Endplate (Cast Iron) w/Seal	1
6	◆◆	2220-0018	1/4"-20 x 5/8" Socket Head Cap Screw	4
7*	**	1720-0104	O-Ring Gasket for Endplate	1
8	◆◆	0300-4101C	Rotor & Shaft Assembly	1
9*	5112029	1005-0002	Super Roller (Standard)	4
10	◆◆	2230-0002	1/4"-20 x 3/8" Set Screw	1
11	◆◆	0100-4101C	Body (Cast Iron) w/Seal	1
12	5017480	2300-0023	Shaft Bearing Cover	1
13	5005175	1320-0016	Adapter & Kit (Coupler)	1

# Roller Pump General Safety Information

1. Use a pressure relief device on the discharge side of the pump to prevent damage from pressure buildup when the pump discharge is blocked or otherwise closed and the power source is still running.
2. **WARNING:** Never pump flammable or explosive fluids such as gasoline, fuel oil, kerosene, etc. Never use in explosive atmospheres. The pump should be used only with liquids compatible with the pump component materials. Failure to follow this warning can result in personal injury and/or property damage and will void the product warranty.
3. Never pump acids (i.e. acid fertilizer) with Super Rollers!
4. Never run the pump faster than maximum recommended speed.
5. Never pump at pressures higher than the maximum recommended pressure.
6. Never pump liquids at temperatures higher than the recommended maximum temperatures (140°F/60°C).
7. Make certain that the power source conforms to the requirements of your equipment.
8. Provide adequate protection in guarding around the moving parts such as the shaft and pulleys.
9. Disconnect power before servicing.
10. Release all pressure within the system before servicing any component.
11. Drain all liquids from the system before servicing any component.
12. Check all hoses for weak or worn condition before each use. Make certain that all connections are tight and secure.
13. Periodically inspect the pump and the system components. Perform routine maintenance as required.
14. Never operate a gasoline engine in an enclosed area. Be sure the area is well ventilated.
15. Use only pipe, hose and fittings rated for the maximum psi rating of the pump.
16. Never use pump for pumping water or other liquids for human or animal consumption.

## Roller Pump Operation & Maintenance

**WARNING:** Never pump corrosive or abrasive liquids as these will cause rapid wear or deterioration of the body, rotor, shaft and seals in the pump. The pump should be used on with liquids compatible with pump component materials. Never exceed maximum specified rpm and pressure. Never run pump dry. Failure to follow this warning will void the product warranty.

### Priming the Pump:

To help prime the pump, keep the inlet or suction line as short as possible with a minimum of bends, elbows and kinks. Make sure all connections are tight and do not leak air. Make sure line strainer is free of debris. If pump does not self-prime, disconnect suction hose, fill with water and reconnect to liquid source. Often a squirt of oil into the ports of the pump will seal clearance and help priming.

### Care of the Pump:

Proper care and maintenance will keep your pump wear at a minimum and will keep it running smoothly and trouble-free for a long time.

### Flush the Pump After Each Use

**One of the common causes of faulty pump performance is “gumming” or corrosion inside the pump. This prevents rollers from moving freely in their rotor slots. Flush the pump with a solution that will neutralize liquid pumped, mixed according to manufacturer’s directions.**

### To Prevent Corrosion:

After cleaning pump as above, flush it with a 50-50 solution of permanent-type automotive antifreeze (containing a rust inhibitor) and water. A rust inhibitor can also be squirted into the ports of the pump. Turn shaft several times to draw protective liquid through pump and coat entire inner surface. Drain pump and plug ports to keep out air during storage. For short periods of idleness, noncorrosive liquids may be left in the pump, but air must be kept out. Plug ports or seal port connections.

Troubleshooting		
Symptom	Probable Cause(s)	Corrective Action
Pump Does Not Prime	Leak in suction line	Check hose and fittings for leaks and correct
	Obstruction in suction line	Inspect hose for debris or loose inner liner in hose
	Suction hose sucked to bottom or side of tank	Cut a notch or "V" in end of suction hose
	Rollers stuck in pump	Disassemble pump and inspect rollers
	Pump seals leaking air	Replace seals
Loss of Pressure	Clogged suction strainer	Check strainer and clean it regularly
	Kinked or blocked suction hose	Inspect suction hose and repair as necessary
	Air leak in inlet side plumbing	Check hose and connections for leaks Use pipe joint sealant and retighten connections
	Relief valve setting too low or weakened spring	Check relief valve and correct setting
	Faulty Gauge	Replace gauge
	Pump seals leak air	Replace seals
	Nozzle orifices worn	Replace nozzles
Pump worn	Repair pump	
Pump will not turn	Corrosion (rust), scale or residue	Loosen endplate bolts. Squirt oil into ports to help free rotor. Retighten bolts.
	Solid object lodged in pump.	Disassemble pump and remove objects

## Piston Type Pressure Relief/Regulating Valves

Bypasses excess fluid. Adjustable to maintain control of line pressure at any pressure within the valve operating range. Selected pressure setting firmly held in place by locknut. Extra large passages to handle large flows.

- Polypropylene with stainless steel spring
- Excellent chemical resistance
- EPDM O-Rings
- Fore pressure to 150 p.s.i.
- 1/4" port for pressure gauge
- 3/4" NPT (M) inlet & (F) outlet connections

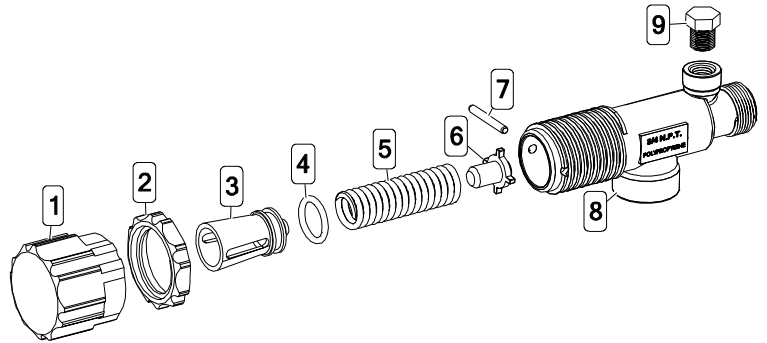

Ref. #	Part #	Mfg. Part #	Description
1	5046270	CP23122-NY	Adjusting Cap, Nylon (Gray)
2	5110266	CP23123-PP	Lock Ring
3	◆◆	CP23124-PP	Spring Retainer
4	**	CP7717-15-EPR	O-Ring, EPDM Rubber
5	**	CP23127-302SS	Spring
6	◆◆	CP23125-PP	Guide Seat
7	**	CP23126-302SS	Retaining Pin
8	CP23121-PP	CP23121-PP	Poly Body (3/4" NPT)
9	5102022	F14	Pipe Plug, 1/4" MNPT

Ref. #	Part #	Mfg. Part #	Description
1	5143199	23120-3/4-PP	Pressure Relief Valve, (3/4" NPT)
2	5168717	PK-AB23120-KIT	Repair Kit, Items Marked **

\*\* Available only in Repair Kit #5168717 (PK-AB23120-KIT)

◆◆ Only Available in Complete Assembly

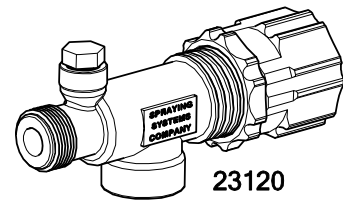

## 3/4" Garden Hose Spray Nozzle

- Heavy-duty aluminum construction, stands up to hard use, will not rust.
- Comfort-grip soft rubber provides a comfortable gripping texture.
- Resists dents, mars and scratches and also protects any surface that comes in contact with nozzle.
- Multiple spray pattern adjusts from a powerful jet stream to a gentle fan spray.
- Ideal for all your spraying needs.

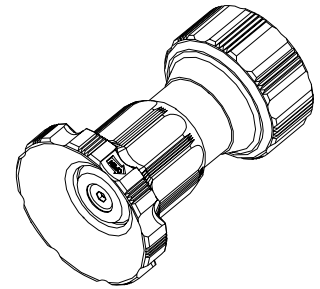

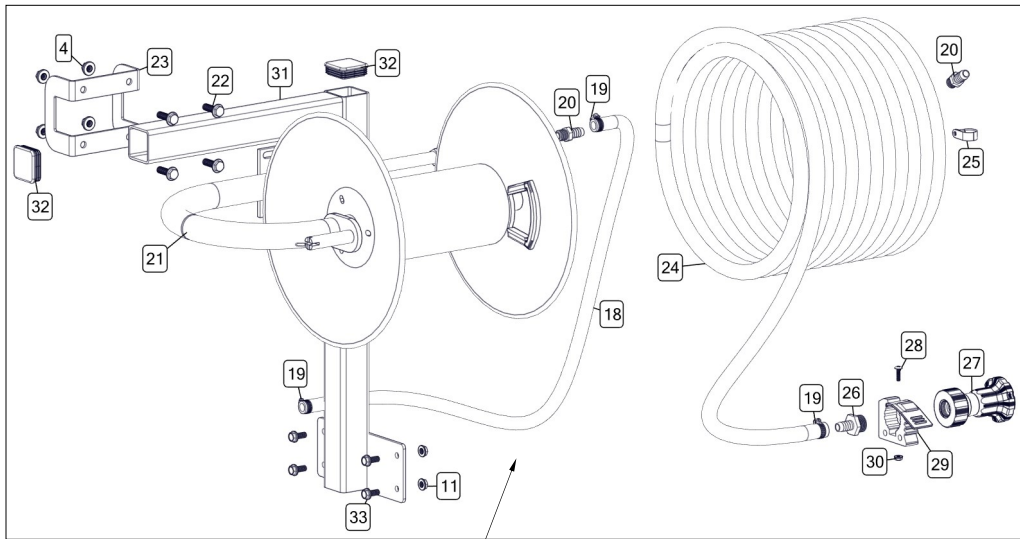

Exploded View:  
 FT-200-4R  
 (5303634)  
 Exploded View

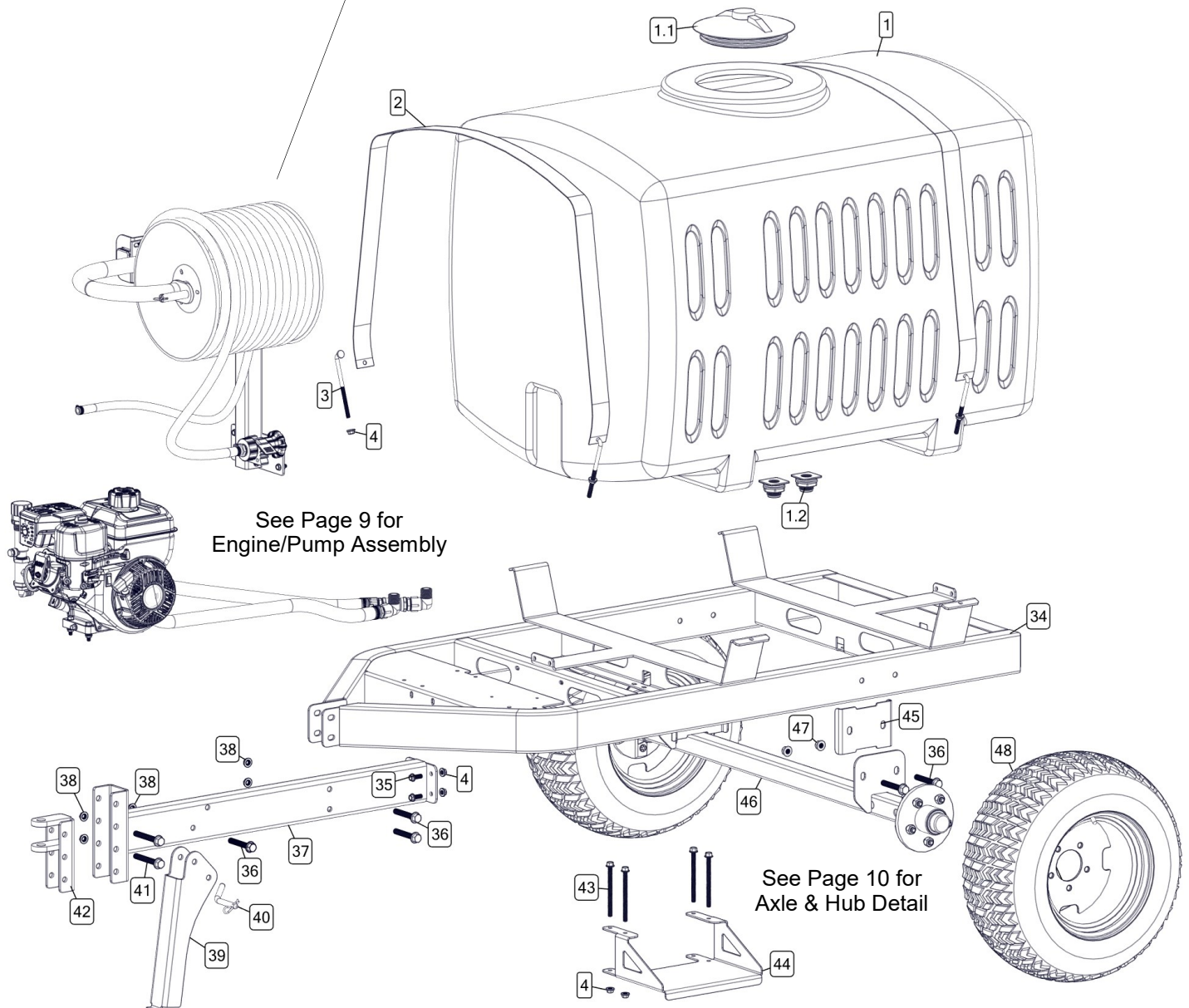



## Exploded View: FT-200-4R (5303634) Parts List:

Ref. #	Part #	Description	Qty
1	5169354	200 Gallon PCO Tank w/Lid and Sump (White)	1
1.1	67398	10" Tank Lid Fillwell & Baffle Vent	1
1.2	5271585	Tank Fitting, 3/4" DT BHF Complete Poly	2
2	5133233	Tank Strap (200 Gal. PCO)	2
3	5034734	3/8-16 x 6.00 Hook Bolt (90°)	4
4	5006259	3/8-16 Serrated Flng Hex Nut	16
5	5281832	3/4" Tank Valve Assembly	1
5.1	5010244	Poly Street Elbow, 3/4" FNPT x 3/4" MNPT	1
5.2	5011140	Poly Close Nipple, 3/4" MNPT	1
5.3	5143190	3/4" "T-800" Brass Ball Valve	1
5.4	5005196	Poly Adapter, 3/4" MNPT x 3/4" MGHT	1
5.5	5016066	1" Rubber Washer	1
5.6	5149037	Poly Swivel, 3/4" Flat Seat Hose Barb	1
5.7	5006209	Poly Knurled Swivel Nut, 3/4" FGHT	1
6	5020967	Hose, 3/4"-1 Brd. x 26"	1
7	5051024	Hose Clamp, 3/4"	4
8	5282499	Filter Assembly	1
8.1	5067127	Poly Fitting, 3/4" MNPT x 3/4" HB	1
8.2	5010249	45° Poly Street Elbow, 3/4" NPT	1
8.3	5116322	3/4" Black Poly Strainer	1
8.3.1	**	Strainer Cap (Available ONLY in Comp. Assy)	1
8.3.2	5072229	EPDM Gasket	1
8.3.3	5116323	40 Mesh Screen	1
8.3.4	**	Strainer Bowl (Available ONLY in Comp. Assy)	1
8.4	5011140	Poly Close Nipple, 3/4" MNPT	1
9	5277100	Engine/Pump [5.5-4R]	1
9.1	5273020	Cast Iron 4-Roller Pump w/ 5/8 to 5/8 Coupler	1
9.1.1	5271757	4-Roller Pump, Cast Iron	1
9.1.2	5005175	Adapter & Kit (Coupler)	1
9.2	5034108	5/16"-24 x 0.625 Hex Bolt	2
9.3	5016026	Lockwasher, 5/16"	2
9.4	5274705	Shield Assembly	1
9.5	5152107	127cc Briggs & Stratton Engine, 5.5 Gross Torque	1
10	5034638	5/16-18 x 1.50 Flng Hex Bolt (Full Thread)	4
11	5006307	5/16-18 Serrated Flng Hex Nut	8
12	5281508	Pump Tee	1
12.1	5011140	Poly Close Nipple, 3/4" MNPT	1
12.2	5010257	Poly Gauge Tee, 3/4" FNPT	1
12.3	5010207	Poly Elbow, 3/4" MNPT x 1/2" HB	1
13	5167034	Gauge, Liquid-Filled, 0-400# p.s.i.	1
14	5143199	Pressure Relief Valve, (3/4" NPT)	1
15	5067127	Poly Fitting, 3/4" MNPT x 3/4" HB	2
16	5020119	Hose, 3/4"-1 Brd. x 36"	1

Ref. #	Part #	Description	Qty
17	5010244	Poly Street Elbow, 3/4" FNPT x 3/4" MNPT	1
18	5020162	Hose, 1/2"-2 Brd. x 40"	1
19	5051114	Hose Clamp, 1/2"	4
20	5067136	Poly Fitting, 3/8" MNPT x 1/2" HB	2
21	5277374	Hose Reel, 3500psi, 3/8" x 200 Ft. Capacity	1
22	5034592	3/8-16 x 1.25 Flng Hex Bolt	4
23	5070232-BLK	Hose Reel Clamp	1
24	5020329	Hose, 1/2" Yellow PVC x 100' (600 psi)	1
25	5051152	3/4" Black Nylon Loom Clamp	1
26	5067121	Poly Hose Fitting, 3/4" MGHT 1/2" HB	1
27	GHN075	Banjo Hose Nozzle	1
28	5117176	#10-24 x 0.75 PH Truss Head Screw	1
29	5051171	Quick Fist Clamp	1
30	5006186	#10-24 Serrated Flng Hex Nut	1
31	5070231-RED	Hose Reel Support	1
32	5046438	2" Square Cap, Black	2
33	5117323	5/16-18 x 0.75 Flng Hex Bolt	4
34	5070134-RED	200 PCO Trailer Frame	1
35	5117307	3/8-16 x 1.00 Flng Hex Bolt	4
36	5034699	1/2-13 x 3.25 Flng Hex Bolt (Full Thread)	8
37	5281831-RED	PCO Trailer Tongue Weldment	1
38	5006337	1/2-13 Serrated Flng Hex Nut	5
39	5165033-BLK	Tongue Stand	1
40	5101202	Bent Clevis Pin (1/2" Dia.)	1
41	5034701	1/2-13 x 3.75 Flng Hex Bolt	2
42	5278045-BLK	Hitch Clevis Weldment	1
43	5034745	3/8-16 x 5.00 Flng Hex Bolt (Full Thread)	4
44	5165034-RED	4" Step	1
45	5051176-BLK	Axle Mount Clamp	2
46	5281829	Trailer Axle	1
46.1	5281830-BLK	Axle Weldment	1
46.1.1	5041113	Machinery Bushing, 1 1/2" O.D. x 1" I.D. x 10 Ga.	2
46.1.2	5006300	1-14 Hex Jam Nut	2
46.1.3	5101081	Cotter Pin, 5/32" x 2-1/4"	2
46.2	5085060	5-Stud Hub Assembly For 1 3/4" Dia Spindle	2
46.2.1	5031178	Cone Bearing (Inner - 1 3/8)	1
46.2.2	5034110	Wheel Bolt (Stud)	5
46.2.3	5006301	1/2-20 Wheel Nut	5
46.2.4	5031177	Cone Bearing (Outer - 1 1/16)	1
46.2.5	5046327	Grease Cap	1
47	5006399	1/2-13 Flng Top-Lock Hex Nut	4
48	5021172-GRY	Turf Tire 23" x 1050-12 w/5-4.5 18" Rim	2

### Engine/Pump Assembly & Plumbing Detail

Refer to parts list above for part numbers

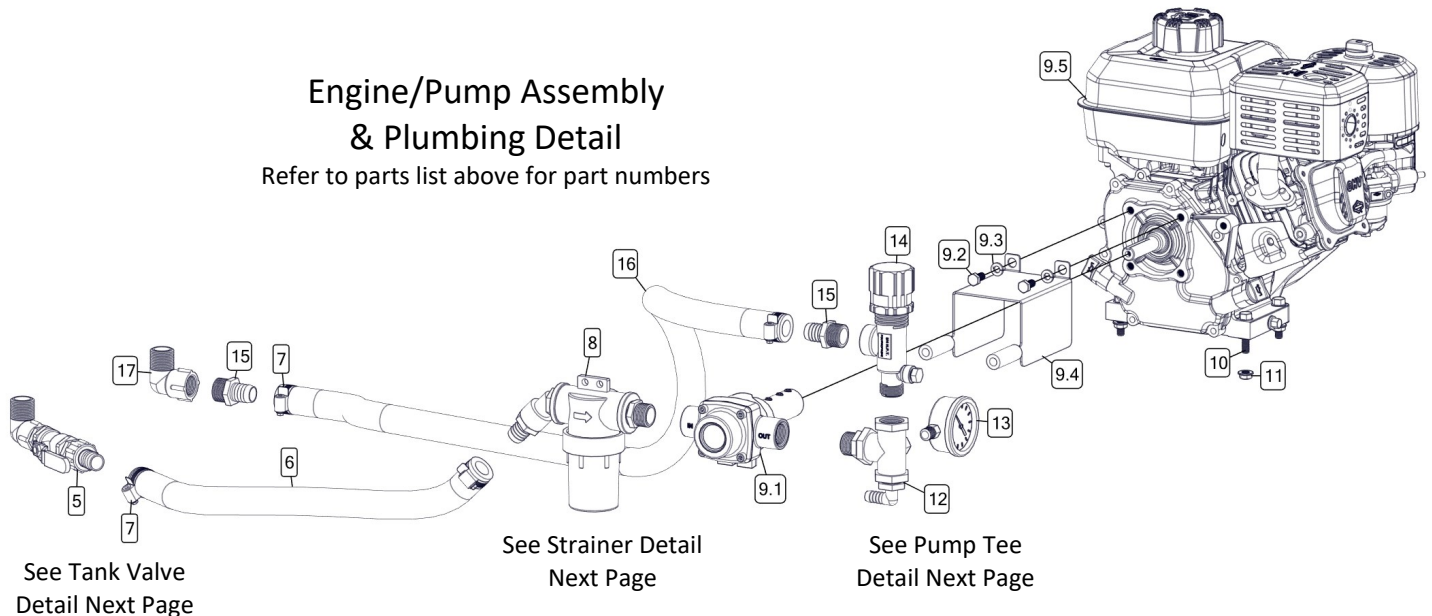

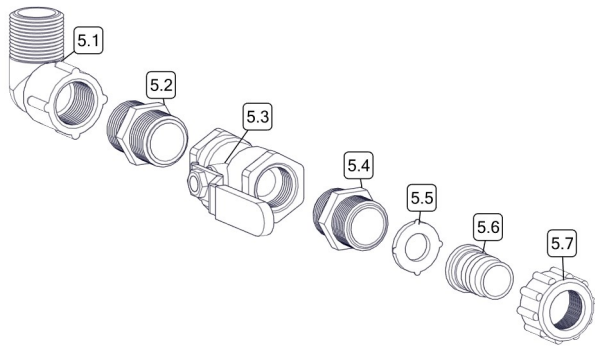

**Tank Valve Detail**

Refer to parts list previous page for part numbers

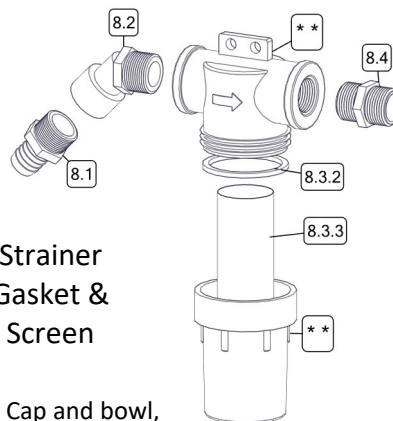

**Strainer  
Gasket &  
Screen**

\*\* : Cap and bowl,  
ONLY available in complete assembly

Refer to parts list previous page  
for part numbers

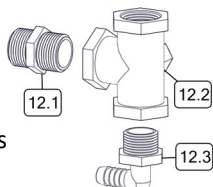

**Pump Tee Detail**

Refer to parts list previous page for part numbers

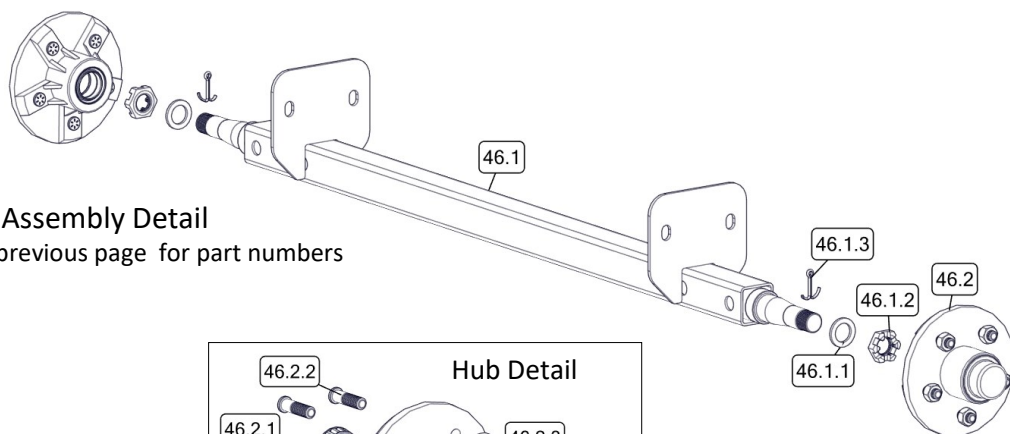

**Axle Assembly Detail**

Refer to parts list previous page for part numbers

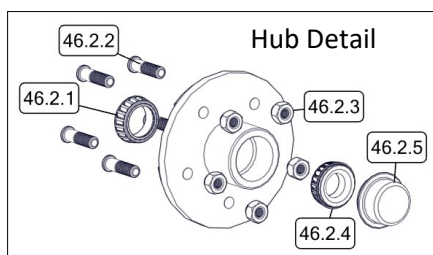

Approx. Dimensions

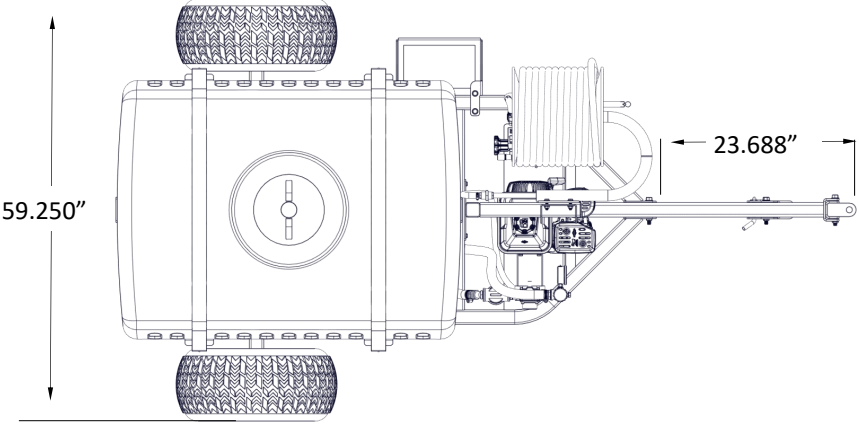
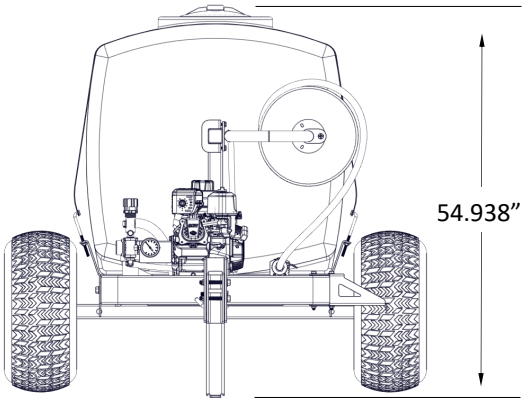
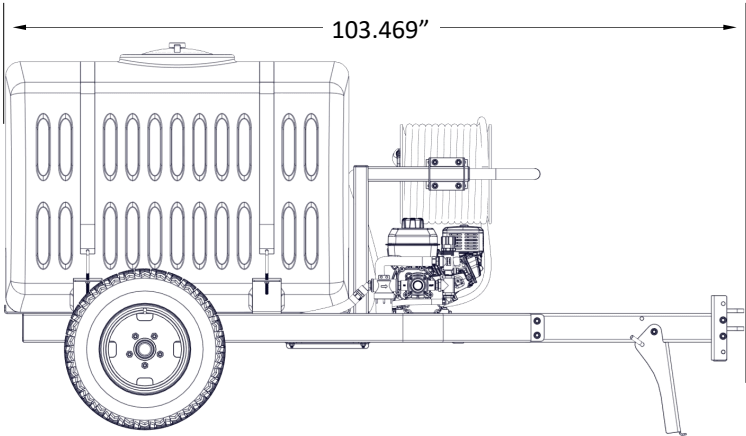

## Warranty Info

### LIMITED WARRANTY FOR NEW FIMCO, IND. EQUIPMENT

**WHO MAY USE THIS LIMITED WARRANTY.** This limited warranty (the "Limited Warranty") is provided by Fimco, Ind. to the original purchaser ("you") of the Equipment (as defined below) from Fimco, Ind. or one of Fimco, Ind.'s authorized dealers. This Limited Warranty does not apply to any subsequent owner or other transferee of the Equipment. THIS LIMITED WARRANTY GIVES YOU SPECIFIC LEGAL RIGHTS, AND YOU MAY ALSO HAVE OTHER RIGHTS WHICH VARY FROM STATE TO STATE.

**WHAT THIS LIMITED WARRANTY COVERS AND FOR HOW LONG.** Fimco, Ind. warrants that any new Equipment will be free from defects in material and workmanship for a period of **one (1) year** (homeowner), **90 days** (commercial user), after delivery of the Equipment to you (the "Warranty Period"). The Warranty Period is not extended if Fimco, Ind. repairs or replaces the Equipment.

**WHAT IS NOT COVERED BY THIS LIMITED WARRANTY.** This Limited Warranty does not apply to: (1) used Equipment; (2) any Equipment that has been altered, changed, repaired or treated since its delivery to you, other than by Fimco, Ind. or its authorized dealers; (3) damage or depreciation due to normal wear and tear; (4) defects or damage due to failure to follow Fimco, Ind.'s operator's manual, specifications or other written instructions, or improper storage, operation, maintenance, application or installation of parts; (5) defects or damage due to misuse, accident or neglect, "acts of God" or other events beyond Fimco, Ind.'s reasonable control; (6) accessories, attachments, tools or parts that were not manufactured by Fimco, Ind., whether or not sold or operated with the Equipment; or (7) rubber parts, such as tires, hoses and grommets.

**HOW TO OBTAIN WARRANTY SERVICE.** To obtain warranty service under this Limited Warranty, you must (1) provide written notice to Fimco, Ind. of the defect during the Warranty Period and within **thirty (30)** days after the defect becomes apparent or the repair becomes necessary, at the following address: Fimco, Ind., 1000 Fimco Lane, North Sioux City, SD 57049; and (2) make the Equipment available to Fimco, Ind. or an authorized dealer within a reasonable period of time. For more information about this Limited Warranty, please call: **800-831-0027**.

**WHAT REMEDIES ARE AVAILABLE UNDER THIS LIMITED WARRANTY.** If the conditions set forth above are fulfilled and the Equipment or any part thereof is found to be defective, Fimco, Ind. shall, at its own cost, and at its option, either repair or replace the defective Equipment or part. Fimco, Ind. will pay for shipping and handling fees to return the repaired or replacement Equipment or part to you.

**LIMITATION OF IMPLIED WARRANTIES AND OTHER REMEDIES.** THE REMEDIES DESCRIBED ABOVE ARE YOUR SOLE AND EXCLUSIVE REMEDIES, AND FIMCO, IND.'S SOLE LIABILITY, FOR ANY BREACH OF THIS LIMITED WARRANTY. TO THE EXTENT APPLICABLE, ANY IMPLIED WARRANTIES, INCLUDING, WITHOUT LIMITATION, THE IMPLIED WARRANTIES OF MERCHANTABILITY AND FITNESS FOR A PARTICULAR PURPOSE, SHALL BE LIMITED IN DURATION TO THE WARRANTY PERIOD, AND THE REMEDIES AVAILABLE FOR BREACH THEREOF SHALL BE LIMITED TO THE REMEDIES AVAILABLE UNDER THIS EXPRESS LIMITED WARRANTY. SOME STATES DO NOT ALLOW LIMITATIONS ON HOW LONG AN IMPLIED WARRANTY LASTS, SO THE ABOVE LIMITATION MAY NOT APPLY TO YOU. IN NO EVENT SHALL FIMCO, IND.'S LIABILITY UNDER THIS LIMITED WARRANTY EXCEED THE ACTUAL AMOUNT PAID BY YOU FOR THE DEFECTIVE EQUIPMENT, NOR SHALL FIMCO, IND. BE LIABLE, UNDER ANY CIRCUMSTANCES, FOR ANY CONSEQUENTIAL, INCIDENTAL, SPECIAL OR PUNITIVE DAMAGES OR LOSSES, WHETHER DIRECT OR INDIRECT. SOME STATES DO NOT ALLOW THE EXCLUSION OR LIMITATION OF INCIDENTAL OR CONSEQUENTIAL DAMAGES, SO THE ABOVE LIMITATION OR EXCLUSION MAY NOT APPLY TO YOU.